



# EUCAR

EUROPEAN COUNCIL FOR AUTOMOTIVE R&D

## **Session 1: Environment and Energy**

### **FP6 Project: HySYS**

**Dr. Jörg Wind**

Manager EC-Research and Hydrogen Projects

DaimlerChrysler

Group Research & Advanced Engineering



# Project general information



<b>Project name:</b>	HySYS – Fuel Cell Hybrid System Component Development
<b>Coordinator:</b>	DaimlerChrysler, Dr. Jörg Wind
<b>Project main partners:</b>	CRF, DC, PSA, Renault, Volvo, VW, AVL, Bosch, Continental Temic, Magna Steyr, Saft, ATB, Fischer
<b>Starting Date:</b>	01.12.2005
<b>Ending Date:</b>	30.11.2009
<b>Budget Total / Funding:</b>	22.7 MEURO / 11.2 MEURO
<b>FP6 Thematic Area:</b>	Sustainable Development, Global Change and Ecosystems



# EUCAR Research Projects in the field of Fuel Cell & Hydrogen

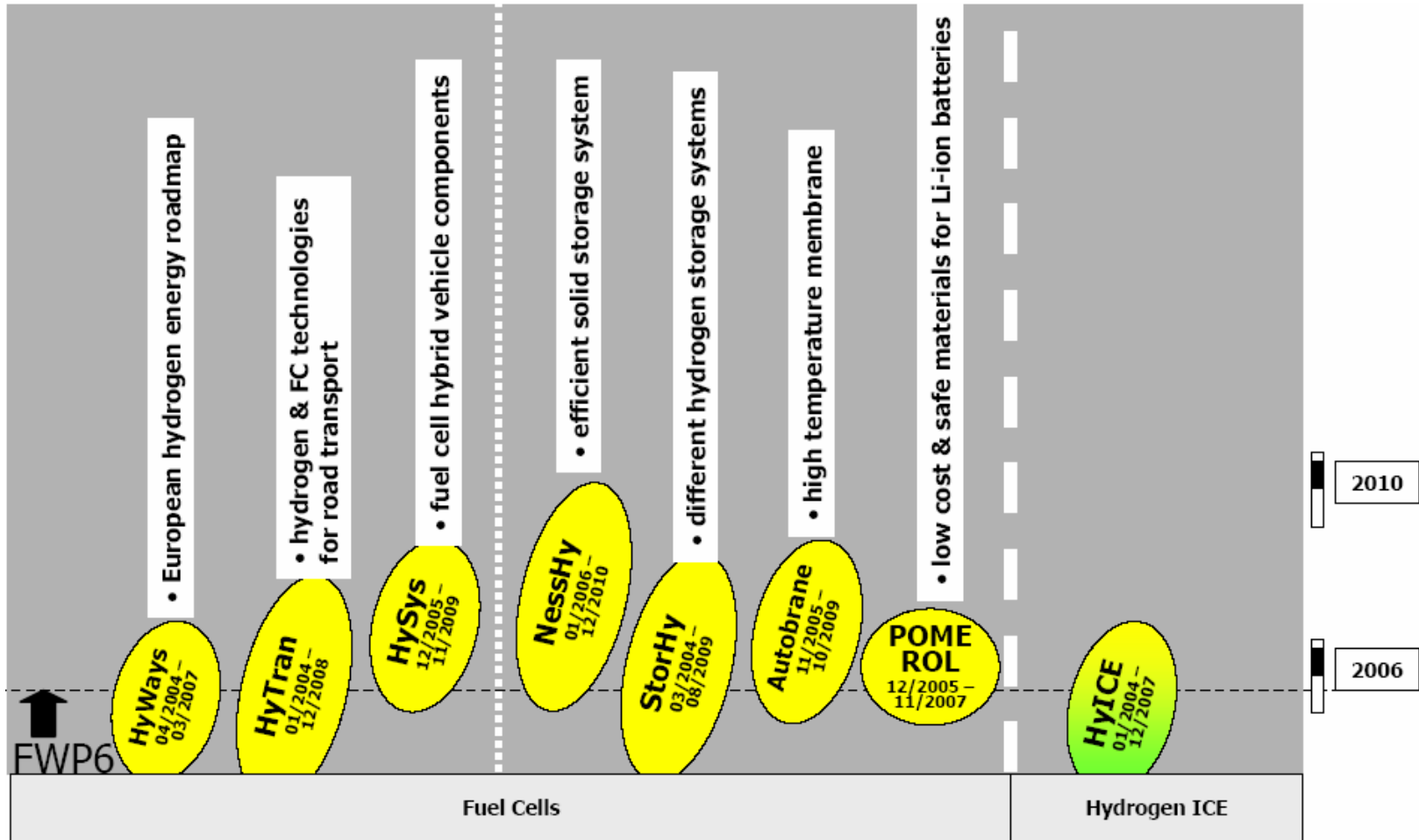



## **Motivation:**

- Improvement of system components for FC-hybrid vehicles is necessary to meet all necessary requirements for mass production
- System components for electric drive trains for FCV and HEV is necessary as well
- Close cooperation of car industry with suppliers is needed for a successful market introduction of FC and ICE-hybrid vehicles
- Involve supplier industry more deeply in FC- and ICE Hybrid component development by cooperation in a European project

## **Objective:**

- Improved low cost FC-system components (air supply, hydrogen supply, humidifier, H<sub>2</sub>-sensors) suitable for mass production
- Improved low cost E-drive components (E-motor, power electronics, battery) suitable for mass production
- Optimised system architecture for low energy consumption and high performance
- All achievements will be validated in vehicles (2 validators)



Project Management (DC)

SP 1000

Standardisation and Requirements (AVL)

SP 2000

- WP 2100 Definition of system and vehicle requirements(DC)
- WP 2200 Identification and analysis of synergies with ICE Hybrids (AVL)
- WP 2300 Codes, Standards and Safety (Renault)
- WP 2400 Training activities (AVL)

FC System Components (DC) **SP 3000**

- WP 3100 Air Supply(DC)
- WP 3200 Humidification (DC)
- WP 3300 H2 sensors (PSA)
- WP 3400 Hydrogen Line (CRF) (Injectors)

Drive Train Components (CRF) **SP 4000**

- WP 4100 Electric drive w. stepup: Bench Test (CRF)
- WP 4200 Electric drive w. DC/AC+DC/DC integration (DC)
- WP 4300 Battery Systems (Saft)

System Level (PSA) **SP 5000**

Vehicle validators:

- WP 5100 Full FC Delivery Van (DC)
- WP 5200 Small Power FC Duty Vehicle (PSA)

System integration aspects:

- WP 5300 Modular system control and assessment of FC hybrid performance (AVL)



# Project Milestones

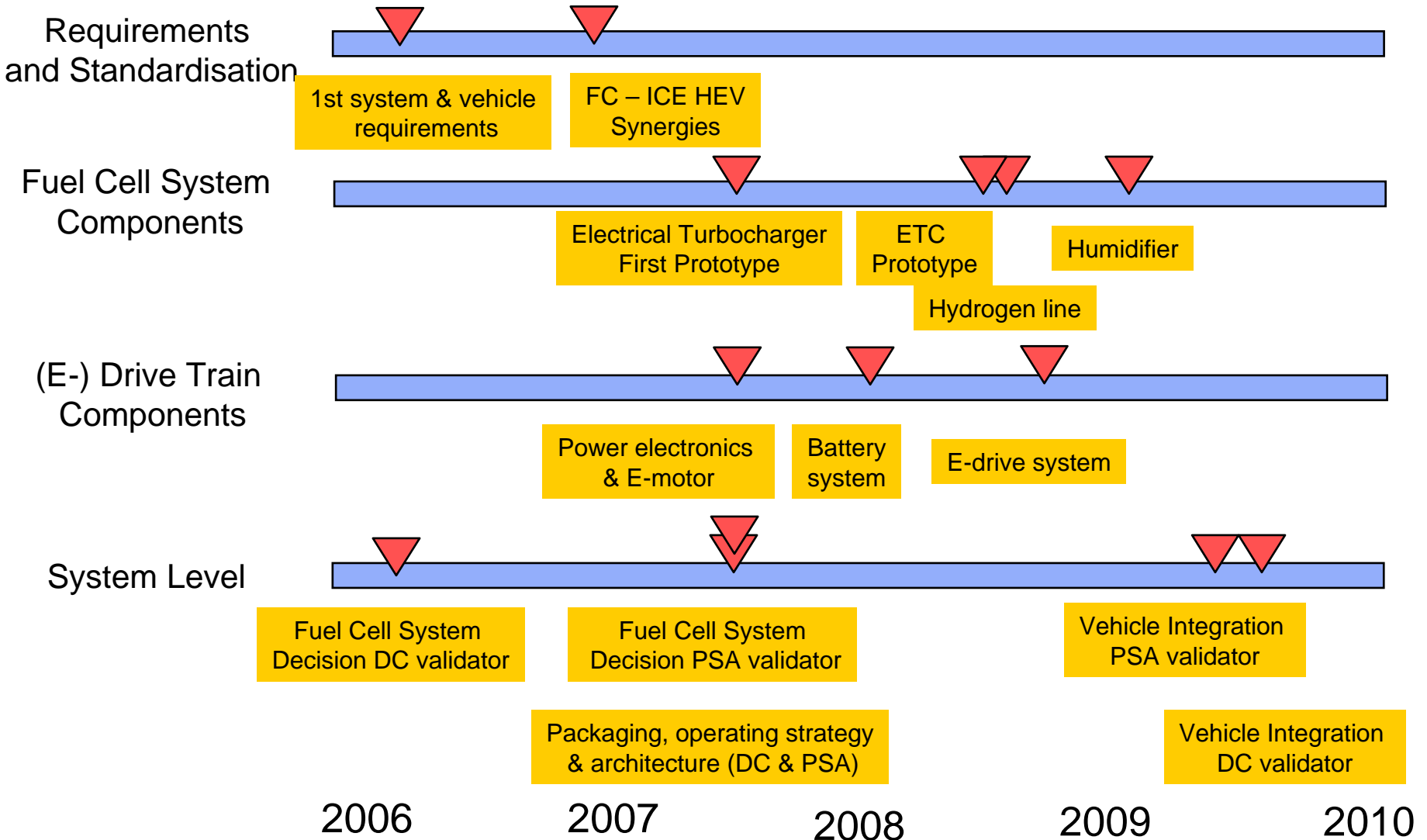



## List of deliverables due until november 2006

Deliverable No[1]	Deliverable title	WP no.	Lead participant	Delivery date [2]	Status
D.2100.1	1st version of report on system and vehicle requirements	2100	DC	February 2006	OK
D.2200.1	Report on common components & modular design for HEV	2200	Bosch	May 2006	OK
D.2200.1	Report on common components & modular design for HEV	2200	Bosch	May 2006	OK
D.3200.1	System architecture and complete system plus related subsystems specifications definition	3200	CRF	May 2006	OK
D.3300.1	Requirements and Specifications for hydrogen sensors for automobile applications	3300	PSA	September 2006	OK
D.3400.1	Complete hydrogen line architecture. Preliminary hydrogen line and related devices/components detailed specifications	3400	CRF	May 2006	OK
D.4100.1	Electric drive and related subsystems architecture and specifications definition	4100	CRF	May 2006	OK
D.4300.1	Batteries specifications	4300	Saft	August 2006	OK
D.5200.1	Operating specifications and test procedures	5200	PSA	August 2006	Shifted to December 2006



<b>Parameter</b>	<b>DC Validator (Sprinter)</b>	<b>PSA Validator</b>
Motor Power (cont/Peak)	70/100 kW	40/70 kW
Fuel Cell Power	70 – 90 kW	20 kW
Gearbox	One gear ratio	One gear ratio
Batterie Lilon	30 – 50 kW, 2 kWh	50 kW, ca. 2.3 kW.h
Weight empty/fully loaded	<= 2.7 t / 3.5 t	1.6 t / 2.2 t
Range at ½ load	> 300 km	350 – 400 km
Vmax	130 km/h @ grade 0%	130 km/h @ grade 0%
Vmax continuous		90 km/h @ grade 0%
Acceleration	0-80km/h < 21 s 0-100 km/h < 37 s	0-50km/h < 7 s 0-100 km/h < 20 s
Climbing ability fully loaded	35%	20 %
Vmax at ½ load on 4% slope	N/A	> 80 km/h



# HySYS - Progress and Results

## FC System Components



### Air supply

**Current Technology: Screw-Compressor**

**Innovative Technology: Electrical Turbocharger (ETC)**

- High Efficiency, especially at part load
- Low Cost, volume and weight
- High Dynamic response
- Noise reduction

**Challenges:**

- High speed rotation (> 100,000 min<sup>-1</sup>)
- Thermal management
- Bearings without lubrication

**Results:**

- Definition of air supply subsystem completed  
(ETC and sensors, including the aerodynamic components, electric motor, power electronic, bearings)

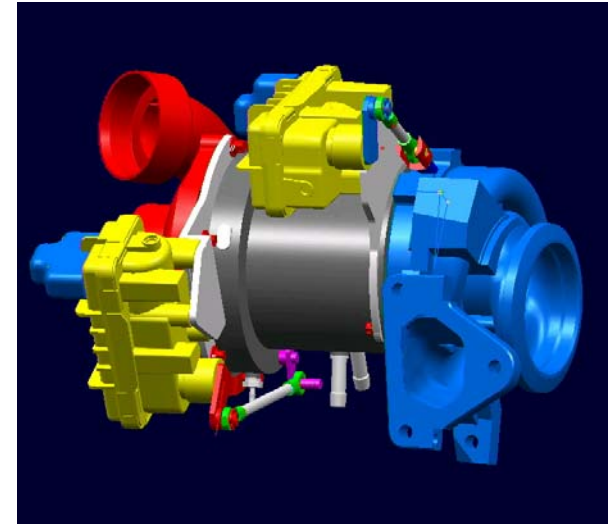

### Hydrogen line

**Current Technology:** standard H<sub>2</sub> line with pressure regulator valves (not fully automated)

**Innovative Technology:** fully automated H<sub>2</sub> line with the Hydrogen Metering Device (HMD)

- dual stage hydrogen pressure reducing system
- fully automatic operation allowed
- regulating FC stack pressure in any working condition (also for high pressure variations)
- fail safe with failure recovery
- being able to improve the life time of the FC system

**Challenges:**

- providing with the fastest FCS dynamics
- assuring high safety level/performance target with a solution for large mass production

**Results:**

- completing the hydrogen line architecture
- preliminary specifications for the hydrogen line
- a new concept for the HMD and its related control unit

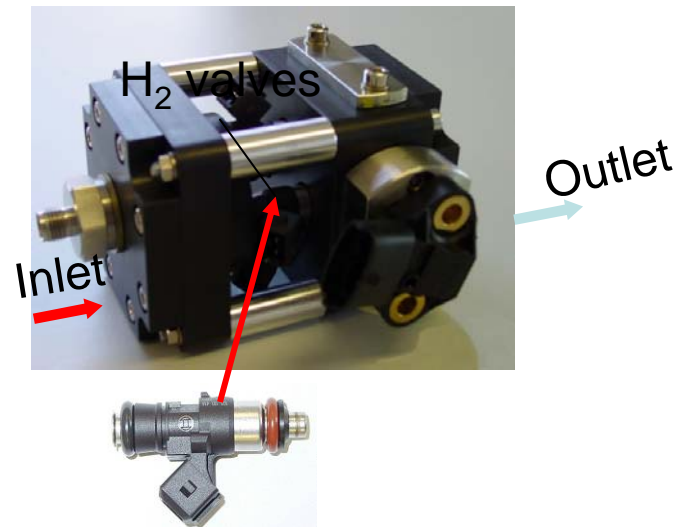



### Humidifier (cathode side)

**Current Technology: Contact humidifier**

**Innovative Technology: Gas-to-gas (membrane) humidifier**

- high packaging density and high humidification efficiency
- low degradation tendency
- low cost materials
- easy production technology

**Challenges:**

- high water vapor transfer rate
- very low oxygen transfer rate = high selectivity
- thermal stability of membrane and potting material

**Results:**

- Definition of humidification system architecture and subsystem specifications



### Humidifier (anode side)

**Current Technology: Contact humidifier**

**Innovative Technology: fuel pump and related electric drive + gas treatment devices**

- high efficiency H2 pump
- specific water separator for the anode stream
- innovative humidification device for correct membrane stack humidification
- H2 pressure regulator for inlet pressure tuneable, high dynamic and fine regulation

**Challenges:**

- Pump compatibility material (friction; surfaces in contact with H2, steam and water)

**Results:**

- hydrogen humidification line (anode recirculation) architecture
- fuel pump preliminary specifications and technology comparison (dynamic vs. volumetric)
- gas treatment devices (water separator, humidifier and fine pressure) regulator preliminary specifications

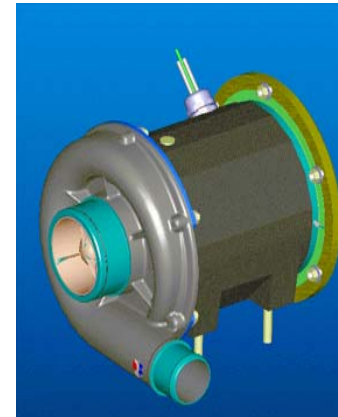



# HySYS - Progress and Results

## FC System Components



### Hydrogen sensors

**Current Technology:** electrochemical sensor, semiconductor sensor, catalytic bead sensor.

**Innovative Technology:** Palladium nanostructures sensor

- Low cost, weight, volume and energy consumption
- Fast response
- No calibration needed
- High gas selectivity
- Integrated design

### Challenges:

- Nanostructures deposition processes
- Nanogaps design
- Electronic integration

### Results:

- Requirements and Specifications for hydrogen sensors for automobile applications

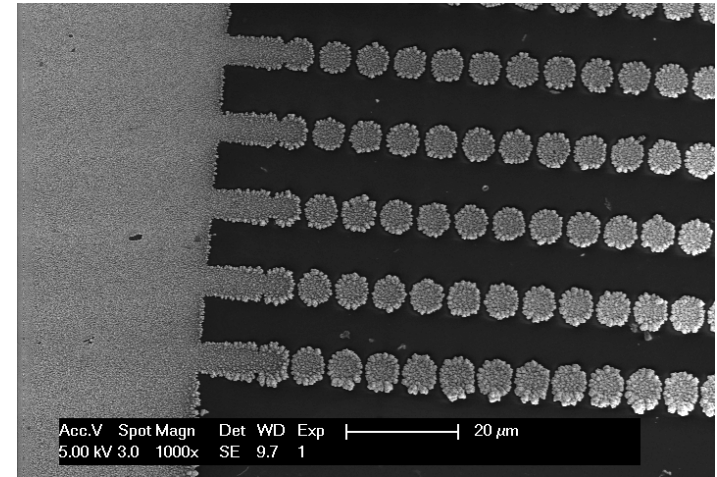



# HySYS - Progress and Results

## Drive Train Components



### E-Drive System

**Current Technology:** AC induction and PM brushless with low liquid cooling temperature (55-60 °C) power electronics

- Innovative Technology:** buried PM synchronous and mixed motors
- e-motor: higher specific torque-power and efficiency
  - power electronics: higher integration and cooling temperature (up to 90°C)
  - HV-HV DC/DC converter: modular solution with high power density

**Challenges:**

- integrate the step-up stage with the traction inverter at low cost (WP4100)
- define an e-drive solution suitable for both validators using the same power electronics components(WP4200)

**Results:**

- e-drive specs and related devices design (optimisation in progress)

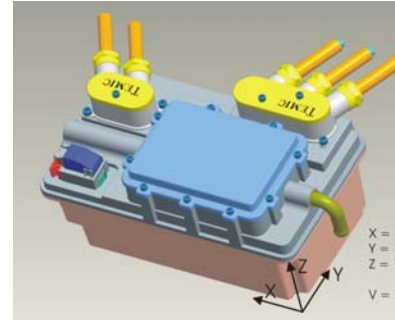

WP4200 Inverter



WP4100 E-motor

### Drive System architecture:

A: Full FC Delivery Van (DC)

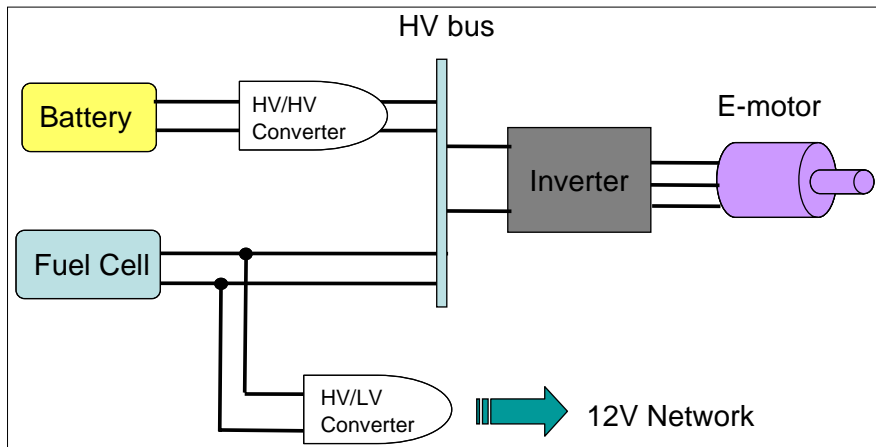

B: Small Power FC Duty Vehicle (PSA)

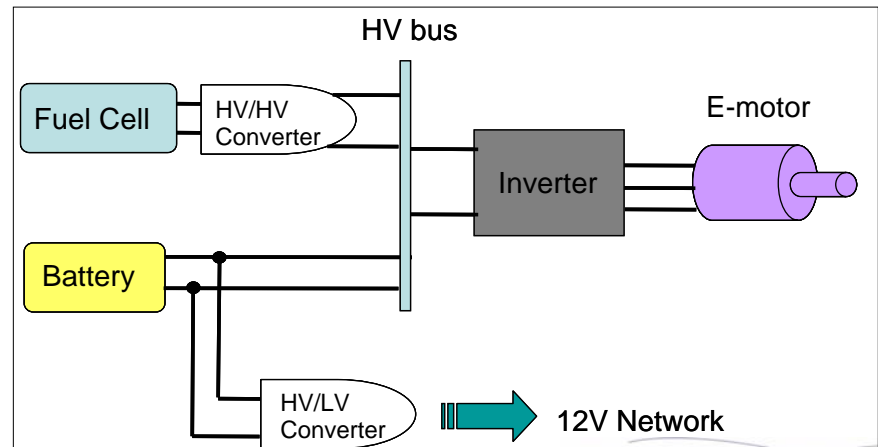



### Battery System

**Current Technology:** Ni-MeH

**Innovative Technology:** Li-ion

- higher specific power: from 1.35 to 2 kW/kg (2 s pulse)
- higher specific energy: from 46 to 63 Wh/kg (at cell level)
- higher efficiency: from 85 to 95% (at P<sub>nom</sub>)
- improved lifetime: from 8 to 15 years

**Challenges:**

- find the best performance vs. cost solution at Battery System level

**Results:**

- Preliminary design review

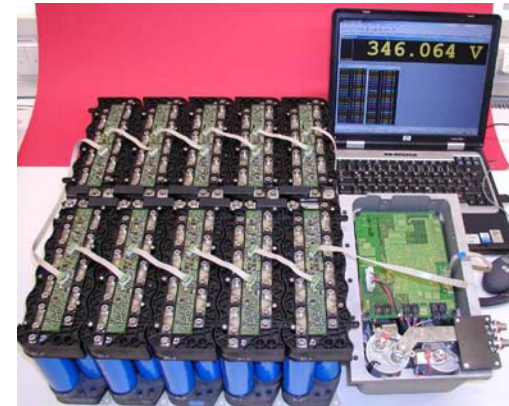

**Battery Modules and BMS**  
(from Lion-heart project)

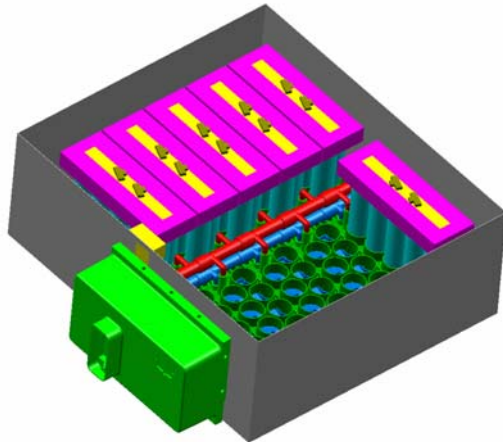

**Hy-SYS Battery System: preliminary design**

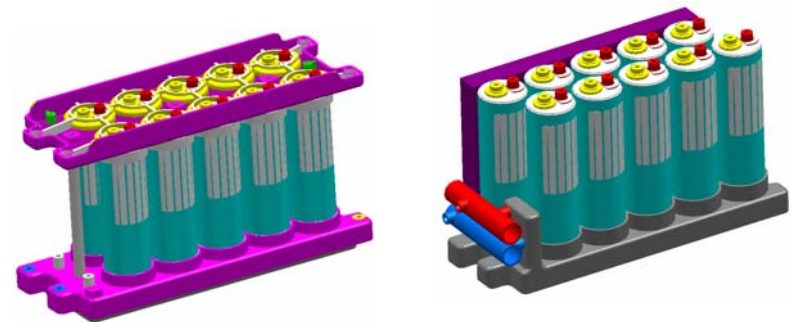

**Hy-SYS Battery Module: possible liquid cooled solutions under investigations**



### Full FC Delivery Van (DC)

#### Integration of:

- Air Supply
- H2 injector
- Humidification system
- E-motor
- DC/DC Converter and Inverter
- Battery

#### Results:

- Decision Base Fuel Cell System
- Vehicle Specifications
- Drive System architecture
- First Packaging Studies

HySys FCS decision matrix Feb 10, 2006

FCS Requirements	Remarks	Possible EUROPEAN Fuel Cell System Alternatives			
		NuCellSys HyWay 1 (F-Cell)	NuCellSys HyWay 23 (B-Class)	DaimlerChrysler F600 FCS	HyTRAN FCS w/ Nuvera Stack
Net Power cont.	kW 70	68.5	62 @ Max 4000	66	(Stack gross 85) >70
Net Power peak	kW 90	68.5	90	66	n.a.
Operating Voltage min	V 250 @ max. load	250	250	235	240
Operating Voltage max	V 430 @ min. load	450	430	450	440
Cost max	TEuro 450 incl. spare parts & support	450	450	>450	<450
Op. Strategy	automotive accessible	yes	yes	partly	yes (t.b.c. EU project)
E/E & bus architecture	automotive accessible	yes	yes	partly	yes (t.b.c. EU project)
Maturity	A-sample min. required	yes	yes	no	partly
NVH	automotive required	yes	yes	partly	yes (t.b.c. EU project)
Package	automotive required	yes	yes	yes	yes (t.b.c. EU project)
System architecture	component required	no	yes	yes	partly
Active DI-water handling	not future-oriented	yes	no	no	no
Design/technology	State-of-the-art required	no	yes	yes	yes
Availability	required	yes	no	no	2008 (t.b.c.)
FCS input date	01.03.2007 required	yes	yes	no	2008 (t.b.c.)



### Small Power FC Duty Vehicle (PSA)

#### Integration of:

- Electric motor
- DC/DC Converter and inverter
- Battery
- H2 sensors

#### Results:

- Vehicle Specifications
- First Packaging Studies

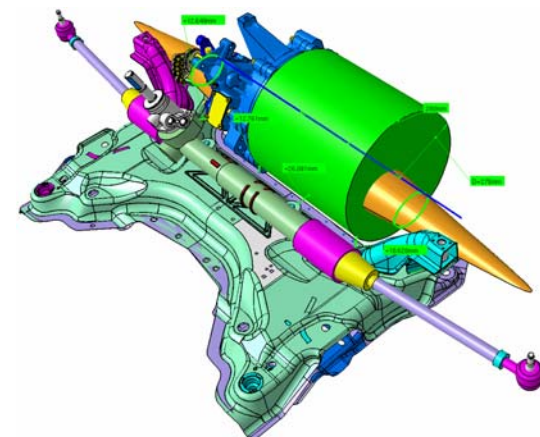



- Expected final results.
  - Low cost automotive electrical turbochargers for air supply with high efficiency and high dynamics
  - Low cost humidifiers with high packaging density
  - Low cost hydrogen sensors for automotive use
  - Effective low cost hydrogen supply line
  - High efficient, high power density drive train
  - Low cost high power Li-Ion batteries
  - Enhanced FC-drive train efficiency
  - Two FC-vehicles to validate the achieved results and visualize the progress



## Use/Impact of expected final results



- It is a goal to use the technical achievements of the project in future fuel cell and ICE-hybrid vehicles for the mass market
- Improved FC-system and e-drive components could be mass-produced and delivered by the suppliers to the automotive industry, providing competitive FC system components and FC vehicles
- The results of HySYS will be one step further towards the hydrogen economy and also a basis for future European research activities
- The validator vehicles built up in HySYS could be prototypes for vehicles in future EC demonstration projects
- HySYS could be one nucleus for the JTI as strategic partners are cooperating in the project
- Availability of low cost FC system components is important for timing of market introduction of FC vehicles and thus for timing of introduction of hydrogen as transport fuel



**Thank you very much for  
your attention**



# BACKUP



# HySYS - Progress and Results

## System Level



### WP 5100: (Base) Fuel Cell System Decision

HySys FCS decision matrix Feb 10, 2006				Possible EUROPEAN Fuel Cell System Alternatives			
FCS Requirements		Remarks		NuCellSys HyWay 1 (F-Cell)	NuCellSys HyWay 23 (B-Class)	DaimlerChrysler F600 FCS	HyTRAN FCS w/ Nuvera Stack
Net Power cont.	kW	70		68.5	(72 @Mar2007) 80	66	(Stack gross 85) ~70
Net Power peak	kW	90		68.5	90	66	n.a.
Operating Voltage min	V	250	@ max. load	250	250	265	240
Operating Voltage max	V	430	@ min. load	450	430	450	440
Cost max	TEuro	450	incl. spare parts & support	450	450	>450	<450
Op. Strategy	automotive		accessible	yes	yes	partly	yes (t.b.c.-EU project)
E/E & bus architecture	automotive		accessible	yes	yes	partly	yes (t.b.c.-EU project)
Maturity	A-sample		min. required	yes	yes	no	partly
NVH	automotive		required	yes	yes	partly	yes (t.b.c.-EU project)
Package	automotive		required	yes	yes	yes	yes (t.b.c.-EU project)
System architecture	component compatibility		required	no	yes	yes	partly
Active DI-water handling			not future-oriented	yes	no	no	no
Design/technology	State-of-the-art		required	no	yes	yes	yes
Availability			required	yes	yes	no	2008 (t.b.c.)
FCS input date	01.03.2007		required	yes	yes	no	2008 (t.b.c.)

